

CSE100 Lecture05
Digital Logic and Circuits
Introduction to Computer Systems

M.A.Hakim Newton

Computer Science and Engineering
Bangladesh University of Engineering and Technology
Dhaka – 1000, Bangladesh

CSE, BUET, 2009

Outline

Boolean Logic

Logic and Circuits

Basic Functions

Extended Functions

Combinatorial Logic

Adder Circuits

Multiplexer

Demultiplexer

Sequential Logic

Clock Signals

Memory Circuits

Counters

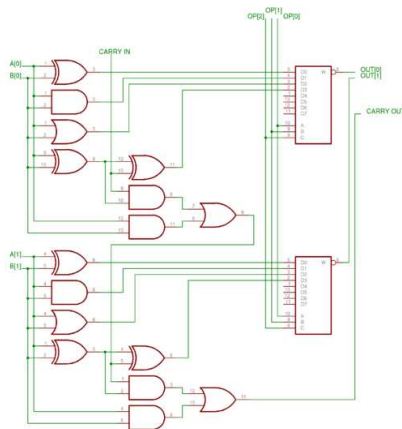

Boolean Logic and Circuits

Boolean Logic

- ▶ Digital computers manipulate only binary whole numbers.
- ▶ Each bit of a binary number represents a Boolean value.
- ▶ 0 represents FALSE and 1 represents TRUE in Boolean logic.

Boolean Circuits

- ▶ Boolean value 0 is represented by a LOW voltage e.g. 0V.
- ▶ Boolean value 1 is represented by a HIGH voltage e.g. 5V.
- ▶ Boolean circuits have inputs and outputs only 0V and 5V.

Conjunction (And): Operation

$$C = A \text{ and } B$$

A	B	C
0	0	0
0	1	0
1	0	0
1	1	1

- ▶ Output = 0, if any input = 0.
- ▶ Output = 1, if both inputs = 1.
- ▶ If one input = 0, output = 0.
- ▶ If one input = 1, output = other input.

More Than Two Inputs

- ▶ Output is 0, if at least one input is 0.
- ▶ Output is 1, if all inputs are 1.

Conjunction (And): Circuit

If any input is 0V

The corresponding diode will conduct. Voltage drop across a diode is almost 0V. So the output is 0V.

If both inputs are 5V

Neither of the diodes will conduct. The voltage at the output is 5V.

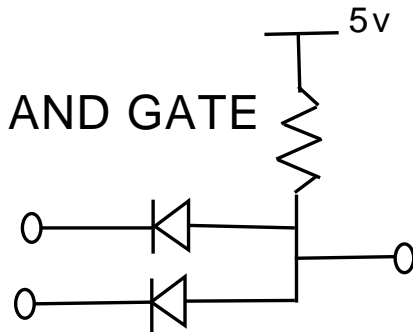

Disjunction (Or): Operation

$$C = A \text{ or } B$$

A	B	C
0	0	0
0	1	1
1	0	1
1	1	1

- ▶ Output = 0, if both inputs = 0.
- ▶ Output = 1, if any input = 1.
- ▶ If one input = 0, output = other input.
- ▶ If one input = 1, output = 1.

More Than Two Inputs

- ▶ Output is 0, if all inputs are 0.
- ▶ Output is 1, if at least one input is 1.

Disjunction (Or): Circuit

If any input is 5V

The corresponding diode will conduct. Voltage drop across a diode is almost 0V. So the output is 5V.

If both inputs are 0V

Neither of the diodes will conduct. The voltage at the output is 0V.

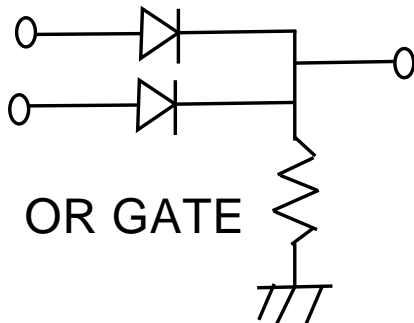

Negation (Not): Operation and Circuit

Input and Output

- ▶ Output 0, if input 1.
- ▶ Output 1, if input 0.

Circuit

If input is 0V, the diode will conduct and the transistor will not conduct. So the output is 5V. If the input is 5V, the diode will not conduct and the transistor will conduct. So the output is 0V.

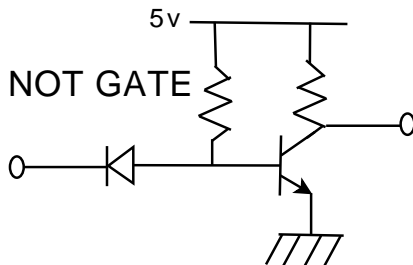

Exclusion (Xor): Operation

$$C = A \text{ xor } B = (A \text{ and } (\text{not } B)) \text{ or } ((\text{not } A) \text{ and } B)$$

A	B	C
0	0	0
0	1	1
1	0	1
1	1	0

- ▶ Output = 0, if both inputs the same.
- ▶ Output = 1, if two inputs different.
- ▶ If one input = 0, output = other input.
- ▶ If one input = 1, output = negation of the other input.

More Than Two Inputs

- ▶ Output is 0, if an even number of inputs are 0.
- ▶ Output is 1, if an odd number of inputs are 1.

One Bit Adder: Operation

A	B	Cin	S	Cout
0	0	0	0	0
0	0	1	1	0
0	1	0	1	0
0	1	1	0	1
1	0	0	1	0
1	0	1	0	1
1	1	0	0	1
1	1	1	1	1

- ▶ Sum 0, if even number of 1.
- ▶ Sum 1, if odd number of 1.
- ▶ Cout 0, if at most one 1.
- ▶ Cout 1, if more than one 1.
- ▶ $S = A \text{ xor } B \text{ xor } Cin$.
- ▶ $Cout = (A \text{ and } B) \text{ or } (A \text{ and } Cin) \text{ or } (B \text{ and } Cin) \text{ or } (A \text{ and } B \text{ and } Cin)$.

One Bit Adder: Circuit and Box

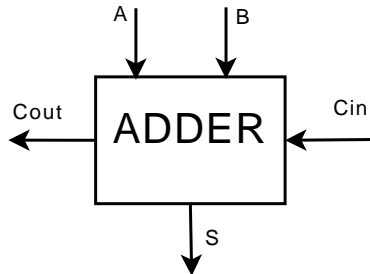
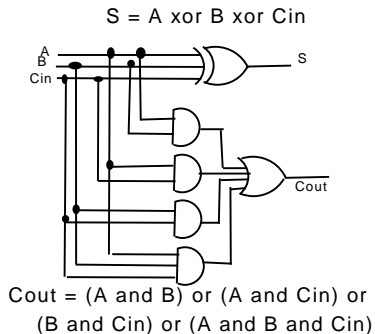

Multiple Bit Cascaded Adder

CASCADED 4-BIT ADDER

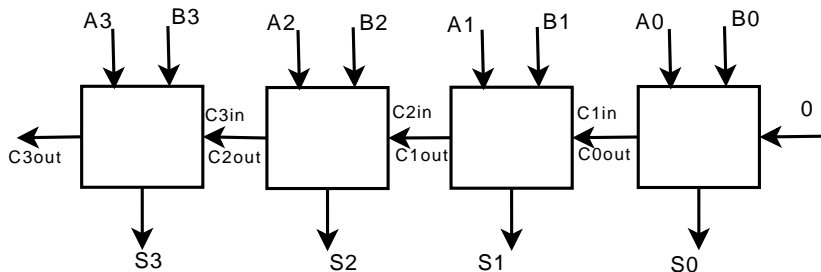

- ▶ One adder for each bit position of the numbers.
- ▶ Cout of a bit is connected to the Cin of the next bit.
- ▶ Cascading is the way to handle multiple bit data.

Multiplexer Circuit (Mux)

- ▶ From a number of input, sending a selected input to the output.
- ▶ If $S1 = 0$ and $S0 = 0$, inverted lines are 1. Therefore, output of the first And gate = $I0$. Output of other And gates are 0. So the final output = $I0$.
- ▶ Similarly for ($S1 = 0, S0 = 1$), ($S1 = 1, S0 = 0$) and ($S1 = 1, S0 = 1$).

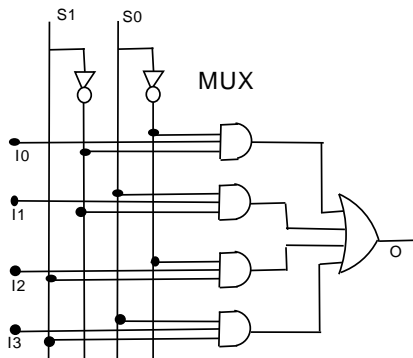

Demultiplexer Circuit (Demux)

- ▶ Send the input to an output, selected from a number of outputs.
- ▶ If $S1 = 0$ and $S0 = 0$, inverted lines are 1. Therefore, output of the first And gate = 1. Output of other And gates are 0.
- ▶ Similarly for $(S1 = 0, S0 = 1)$, $(S1 = 1, S0 = 0)$ and $(S1 = 1, S0 = 1)$.

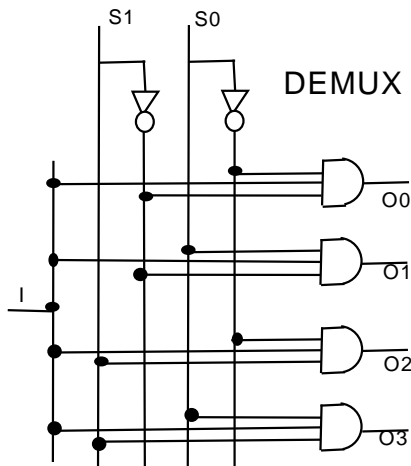

Clock Signals

- ▶ Normally generated by crystals.
- ▶ Normally high or low levels.
- ▶ if Pulse, More convenient for use.
- ▶ Everything inside a computer is normally synchronised with a high speed master clock.

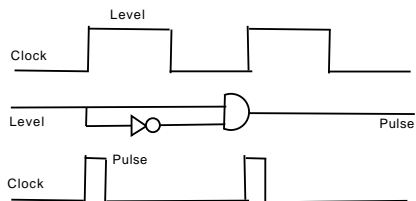

Memory Circuits: FlipFlops

- ▶ Hold data just by feeding output to the input.
- ▶ Operation Table

Clk	J	K	Q	Q'
1	0	0	H	H
1	0	1	0	1
1	1	0	1	0
1	1	1	T	T
0	-	-	-	H

H = Hold

T = Toggle

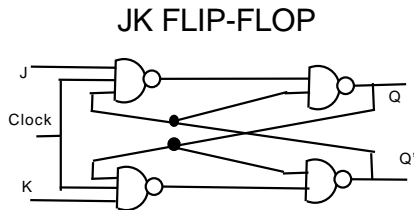

Counters

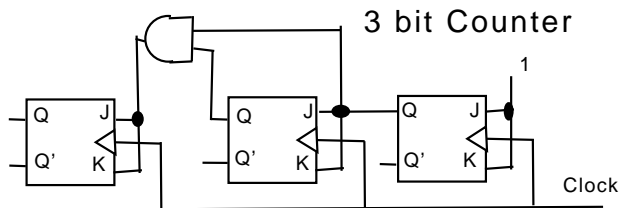

3 bit Counter

000
001
010
011
100
101
110
111

- ▶ The right most bit flips every time with the clock.
- ▶ Each of the other bits flips when all previous bits are 1.
- ▶ Both J and K are the same either to hold or toggle.